

NU1005/6: 5V Full Bridge Driver for High Integration, High Efficiency and Low Cost Wireless Power Transmitter

1 Feature

- Input Voltage: 4.0V to 5.5V
- Output Power: 2.5W (NU1005) and 5W (NU1006)
- Integrated High Efficiency Full Bridge FETs
- Integrated FET Driver Optimized for Low EMI
- Integrated 2.5V LDO to Bias External Circuit and Provide Reference Voltage
- High Accuracy, High Speed, Lossless Current Measurement for FOD and In-Band Communication
- Input Under-Voltage Lockout
- Short-Circuit Protection
- Thermal Shutdown
- 3mm x 3mm QFN Package

2 Applications

- Wireless Power Transmitter Compliant with WPC V1.2
- Wireless Power Transmitter for Smartwatches and Wearables
- General Wireless Power Transmitter for Consumer, Industrial and Medical Applications
- Motor Drivers

3 Descriptions

NU1005/6 is a highly integrated 5V full bridge power IC optimized for wireless power transmitter solutions. It works with transmitter controller NU1300 to create a low-cost and high-performance wireless power transmitter compliant with WPC 1.2 or customized for any customer-requested solutions. The device integrates all critical functions; such as high-efficiency power FETs, low EMI FET driver, bootstrap circuit, 2.5V LDO and lossless current measurement. The proprietary current-measurement circuit provides accurate current reading used by FOD (Foreign Object Detection) power measurement and in-band communication. It eliminates the current-sense resistor and amplifier circuit, and thus saves cost and improves efficiency.

The IC also includes protection functions such as input under-voltage lockout, short-circuit protection, and thermal shutdown. These provisions further enhance the reliability of the total system solution.

The device is housed in a thermally enhanced 16-pin 3mm×3mm QFN package.

4 Pin Configuration and Functions

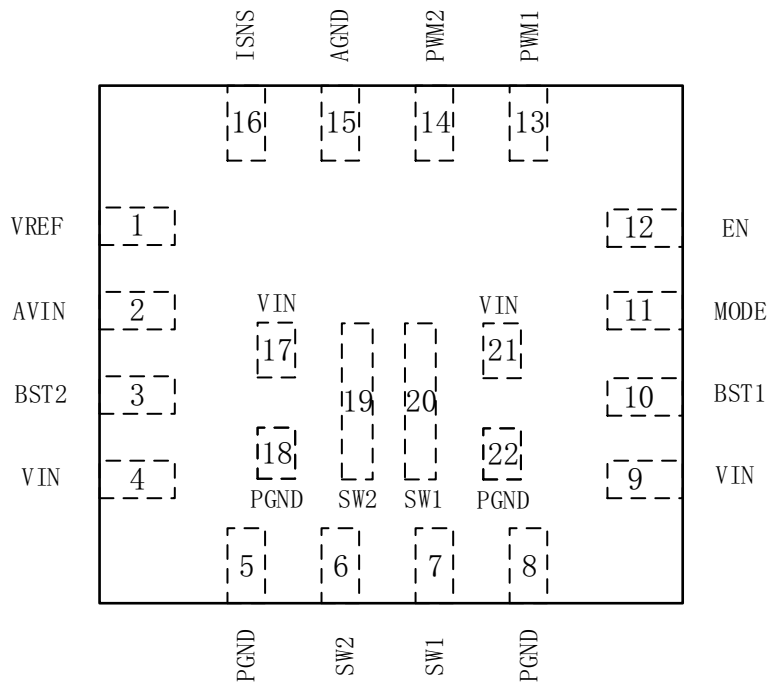

16-Pin QFN
Top View

Pin		I/O	Description
Name	No.		
VREF	1	0	Output of the 2.5V LDO
AVIN	2	-	Signal power input pin
BST2	3	I/O	Supply rail for the high-side gate driver of Q3 as shown in the Block Diagram . Connect a ceramic capacitor between the BST2 and SW2 pins
VIN	4, 9, 17, 21	-	Power input pin. This pin is connected to the input of the full bridge circuit.
PGND	5, 8, 18, 22	-	Power ground pin. This pin is connected to the ground of the full bridge circuit.
SW2	6, 19	0	Switch node of the half-bridge FETs Q3 and Q4, as shown in the Block Diagram .
SW1	7, 20	0	Switch node of the half-bridge FETs Q1 and Q2, as shown in the Block Diagram .

BST1	10	I/O	Supply rail for the high-side gate driver of Q1. Connect a ceramic capacitor between the BST1 and SW1 pins
MODE	11	I	Logic input to program the PWM1 and PWM2 function. See Application Description for details. MODE logic is detected at power up, and can only be reset with power recycling.
EN	12	I	Enable input of the IC. Pull the pin low or keep it floating to disable the IC and open all the FETs. Logic HIGH enables the IC. The EN pin voltage needs to stay below the voltage of the AVIN pin. Otherwise, a resistor of 1K Ω is recommended in series with the pin to limit its current.
PWM1	13	I	PWM logic input to the FET Q1 and Q2 as shown in the Block Diagram . Logic HIGH turns on the high-side FET Q1, and turns off the low-side FET Q2. Logic LOW turns on the low-side FET and turns off the high-side FET. When PWM input is in the tri-state mode, both Q1 and Q2 are turned off. The switching slew rate and dead-time are internally controlled by the IC.
PWM2	14	I	PWM logic input to the FET Q3 and Q4 as shown in the Block Diagram . Logic high turns on the high-side FET Q3, and turns off the low-side FET Q4. Logic low turns on the low-side FET and turns off the high-side FET. When PWM input is in the tri-state mode, both Q3 and Q4 are turned off. The switching slew rate and dead-time are internally controlled by the IC.
AGND	15	-	Analog ground of the IC
ISNS	16	O	Current sense output. When connected with an external resistor, the voltage at the pin is proportional to the input current.

5 Specifications

5.1 Absolute Maximum Ratings

	MIN	MAX	UNIT
SW1, SW2	-0.3	12	V
PWM1, PWM2, VREF, VIN, AVIN, EN, MODE, ISNS	-0.3	7	V
BST1	-0.3	7+SW1	V
BST2	-0.3	7+SW2	V
Operating junction Temperature, T _j	-40	125	°C
Storage Temperature, T _{stg}	-55	150	°C

5.2 ESD Ratings

		UNIT
Human Body Model	+/-1000	V
Charged Device Model	+/-500	V

5.3 Package Thermal Ratings

		UNIT
Junction-to-ambient thermal resistance, R _{θJA}	64.3	°C/W

5.4 Electrical Characteristics

VIN=AVIN=5V, F_{sw}=200KHz, T_j=-40 °C to 125°C(unless otherwise noted)

PARAMETERS		TEST CONDITIONS	MIN	TYP	MAX	UNIT
INPUT						
V _{UVLO}	Under-voltage lock out threshold	AVIN ramps up	3.3	3.6	3.8	V
V _{UVLO_HYS}	Under-voltage lock out hysteresis voltage	AVIN ramps down		400		mV
I _{IN}	Input operating current (I _{VIN} +I _{AVIN})	No switching, EN=logic high			2	mA
I _{SD}	Input shutdown current (I _{VIN} +I _{AVIN})	T _j =-40°C to 85°C, EN=logic low			3	μA
POWER DEVICES and DRIVERS						
I _{SW_LEAK}	SW pin leakage current	V _{sw} =5V or V _{sw} =0V		0.1		μA
V _{BST_FW}	Bootstrap forward voltage	I _{BST} =300 μA			500	mV

I _{BST_LEAK}	Bootstrap leakage current	V _{BST} =5V			2	μA
PWM, MODE and ENABLE INPUTS						
V _H	PWM logic high	Input rising	2.65			V
V _L	PWM logic low	Input falling			0.45	V
V _{TRI}	Tri state voltage	Input rising and falling	1.2		1.9	V
T _{ACT}	Tri state activation timing			100		ns
V _{EH} , V _{MODEH}	EN pin and MODE pin high	Input rising	2.65			V
V _{EL} , V _{MODEL}	EN pin and MODE pin low	Input falling			0.45	V
I _{PWM}	PWM pin input bias current	V _{PWM} =logic high		15		μA
		V _{PWM} =logic low		-15		μA
R _{EN}	Enable pin input impedance	Pull down to GND		1		MΩ
REFERENCE OUTPUT						
V _{REF}	2.5V reference voltage	Temp, line and load	2.45	2.5	2.55	V
I _{REF}	Reference voltage maximum supply current		10			mA
PROTECTIONS						
T _{OTP}	Over temperature protection point	Temp rising		155		°C
T _{OTP_HYS}	Over temperature protection hysteresis	Temp rising and falling		30		°C
I _{SC}	High-side short circuit protection point	NU1006 NU1005		8 4		A
T _{SC}	SC protection time out period			20		ms
Current Sense						
K _{SNS}	Current amplification factor, I _{vin} / I _{SNS}	I _{vin} =1.6A for NU1006 or I _{vin} =0.8A for NU1005, T _j =0 °C to 125°C	6624	6900	7176	
I _{offset}	Current amplification offset, I _{SNS} *K _{SNS} -I _{vin}	I _{vin} =1.6A for NU1006 or I _{vin} =0.8A for NU1005, T _j =0 °C to 125°C	-48	0	48	mA

6 Block Diagram

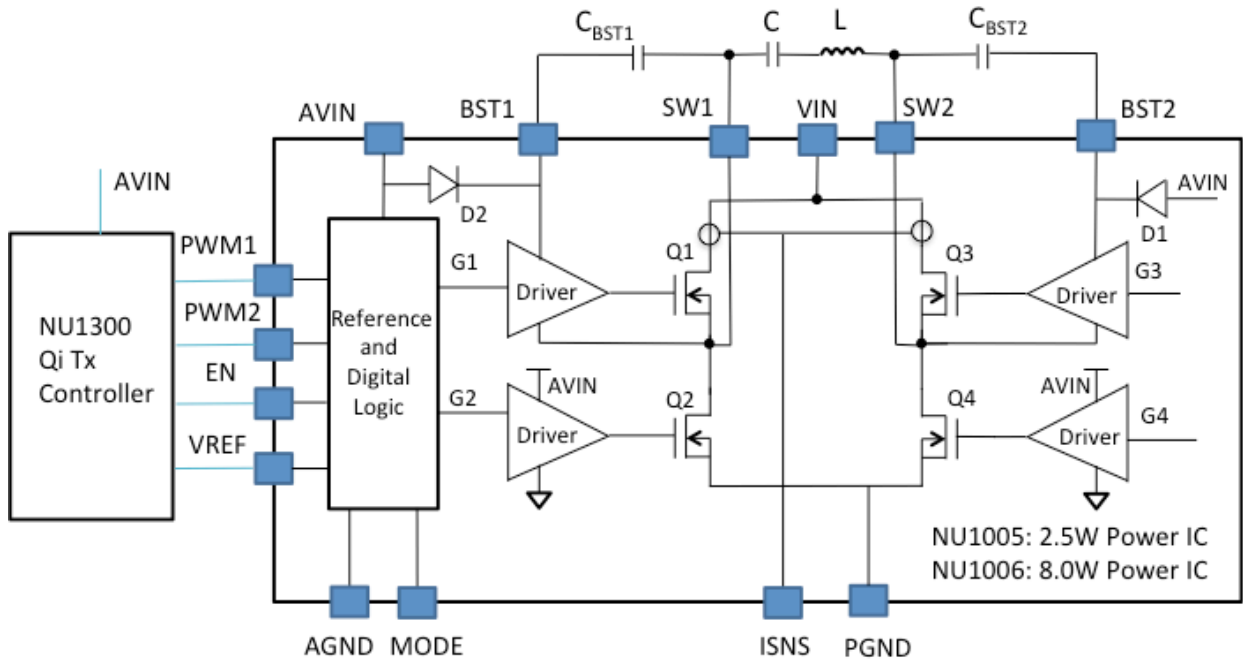

7 Typical Characteristics

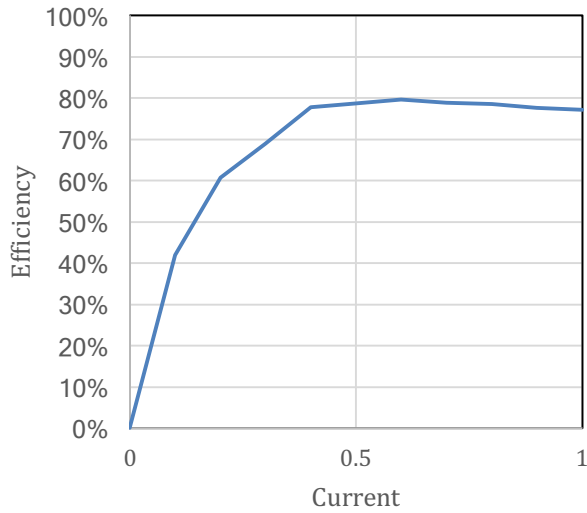

Figure 1. Power efficiency at 5V Vin

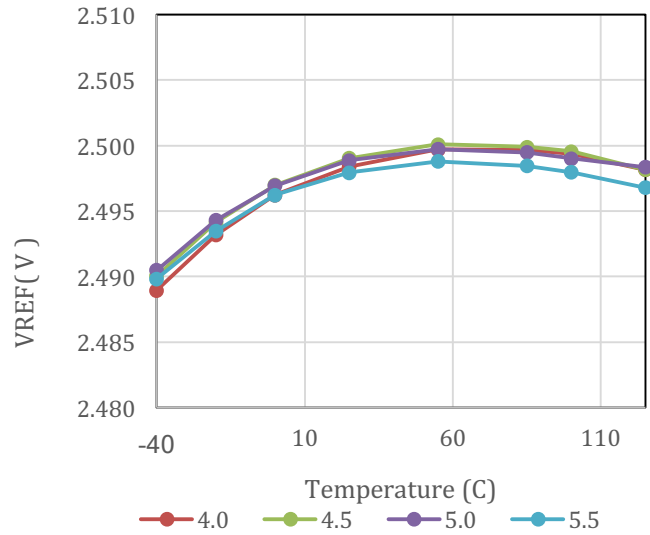

Figure 2. VREF temperature curve at four input voltages

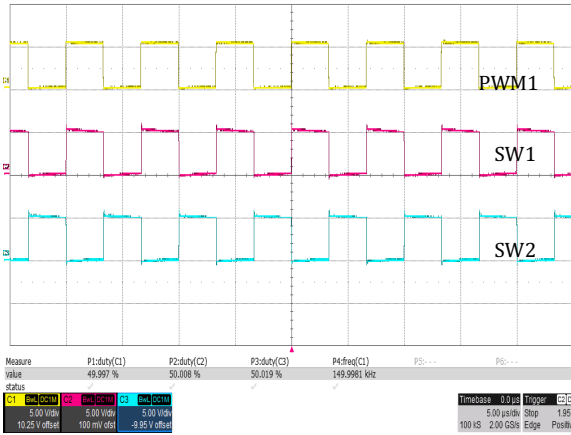

Figure 3. MODE=0, PWM1, SW1 and SW2

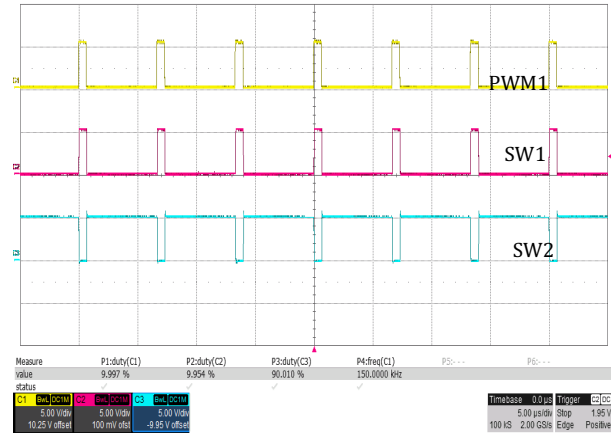

Figure 4. MODE=0, PWM1, SW1 and SW2

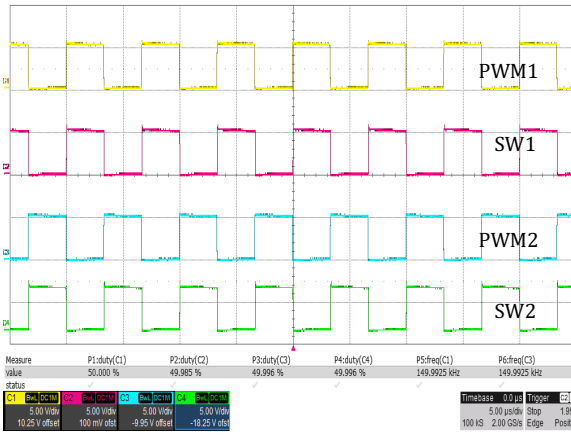

Figure 5. MODE=1, PWM1, SW1, PWM2 and SW2

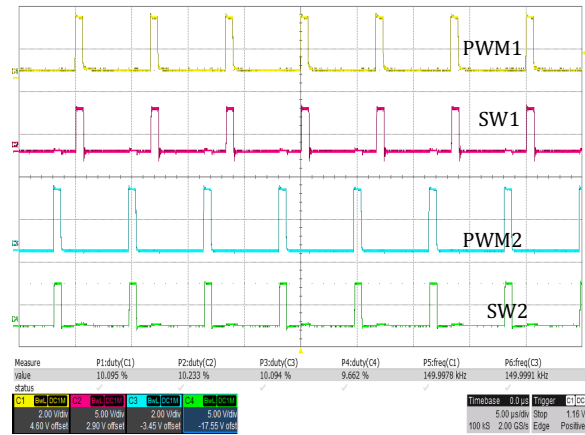

Figure 6. MODE=1, PWM1, SW1, PWM2 and SW2

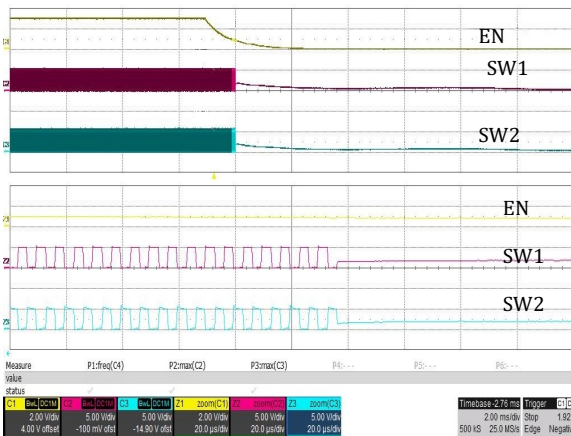

Figure 7. EN Off. EN, SW1 and SW2

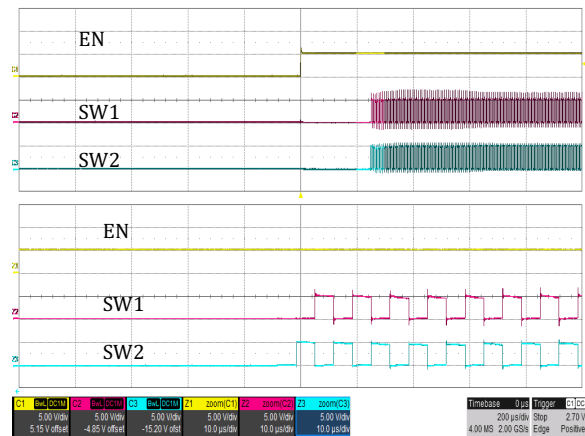

Figure 8. EN On. EN, SW1 and SW2

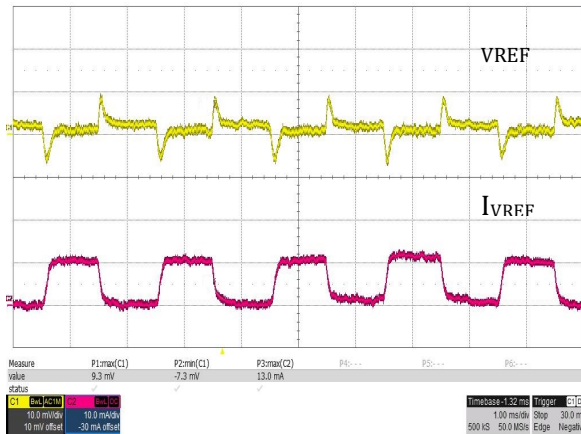

Figure 9. VREF Load Transient. VREF and IVREF

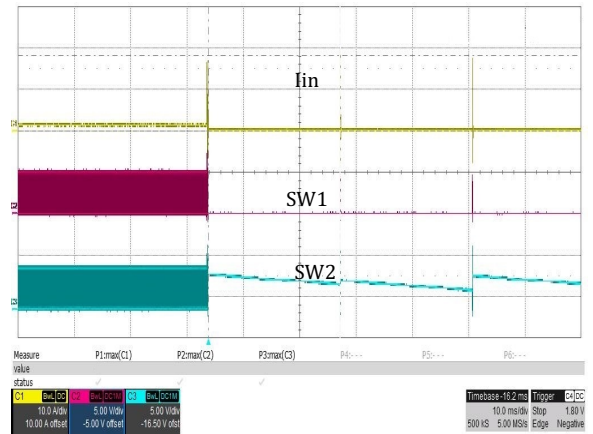

Figure 10. Short Circuit Protection. Input current, SW1 and SW2

8 Application Descriptions

8.1 Input Voltage

The IC has two power input pins. VIN is connected to the power FETs of the full bridge, and conducts the high current for power transfer. Connect a decoupling capacitor of no less than 10 μ F close to the pin to filter the switching current.

AVIN is an analog power input pin, which is used to power IC analog signal and digital circuit including the 2.5V LDO. An Under-Voltage Lockout (UVLO) circuit monitors the voltage of this pin and disables the IC operation when the AVIN voltage falls below the UVLO threshold.

An RC low-pass filter is recommended for this pin to ensure the operation of sensitive IC circuit. Use a resistor less than 1 Ω and capacitor higher than 10 μ F for the filter. A resistor higher than 1 Ω can cause IC chattering when operating near UVLO threshold due to increased impedance of the power source. For normal operation, the input of the RC filter needs to be connected to the VIN pin.

8.2 MODE and PWM Control

When the MODE pin is at logic HIGH, the PWM1 input controls the PWM of Q1 and Q2, and the PWM2 input controls the PWM of Q3 and Q4 as shown in the **Block Diagram**. The PWM1 and PWM2 can independently control the SW1 and SW2 duty cycle and frequency. For a typical WPC transmitter, the PWM1 and PWM2 are complementary in logic and have 50% duty cycle at frequency range of 100KHz to 205KHz. When reaching 205KHz, the

duty cycle of PWM1 and PWM2 can be reduced below 50% to further limit the power output.

When the MODE pin at logic LOW, the PWM2 input is disabled, and PWM1 input controls all 4 FET switches. Logic HIGH at the PWM1 input turns on Q1 and Q4 and keeps Q2 and Q3 off. Logic LOW flips the on/off states of all 4 switches. In a typical WPC wireless power transmitter, the frequency and duty cycle of the PWM1 input are modulated to regulate the transmitter's power output.

Fig. 3 to Fig. 6 illustrate the operation of PWM control under two MODE logics.

The logic of the MODE pin is detected and latched during IC power up. In order to change the MODE logic, the IC has to go through a POR (power-on-reset) event.

When PWM input logic first enters tri-state either from logic HIGH or logic LOW, the ON or OFF states of its controlled FETs stay the same. If the PWM input stays in the tri-state for more than T_{ACT} , its controlled FETs are all turned off, and the corresponding SW output becomes high impedance. The FETs stay off until the PWM logic reaches logic HIGH or logic LOW threshold. This operation applies to both MODE logics.

8.3 Short Circuit Protection

NU1005/6 integrates a reliable short-circuit protection circuit. It protects the input power source and IC if the SW pin is shorted to the ground either directly or indirectly due to external component failures.

Current of the high-side FET Q1 and Q3 is sensed and compared to the short-circuit protection threshold (I_{sc}) during every switching cycle. In each cycle, if the current exceeds the threshold, the internal up-and-down counter counts up by 1. If the current signal fails to reach the threshold during a switching cycle, the counter counts down by 1 until reaching 0. If the output of the counter reaches 7, the short circuit protection is triggered, and all 4 internal FETs are turned off regardless of the PWM inputs. The IC will attempt to restart after a time-out period of 20ms typically.

8.4 VREF Output

The VREF pin is connected to the 2.5V output of an integrated LDO. The maximum output current of the LDO is guaranteed for 10mA. The accuracy of the VREF voltage is +/-2.0% across temperature, line and load. Therefore, it can be used as the supply voltage as well as a reference voltage to external IC and circuit. To use with NU1300, connect the VREF pin of NU1005/6 to the reference input pin of the controller. It is recommended to connect a decoupling capacitor of 1 μ F to 10 μ F to the VREF pin. Capacitor values outside the range may cause instability of the internal linear regulator. A minimum resistor load of 5K Ω is recommended on the VREF output.

8.5 Current Sense

NU1005/6 has unique current-sense circuit that measures input current and reports it on the I_{SNS} pin. The output current on the I_{SNS} pin is directly proportional to the input current, and the ratio is defined by parameter K_{sns} listed in the **Specifications**. A resistor, as shown in Circuit A of Fig. 11, can be connected to the pin to generate a voltage proportional to the input current. Select the resistor using the following equation.

$$R_{sns} = \frac{V_{sns} * K_{sns}}{I_{in}}$$

Where

R_{sns} = resistor connected to the I_{sns} pin

V_{sns} = voltage at the I_{sns} pin

I_{in} = input current

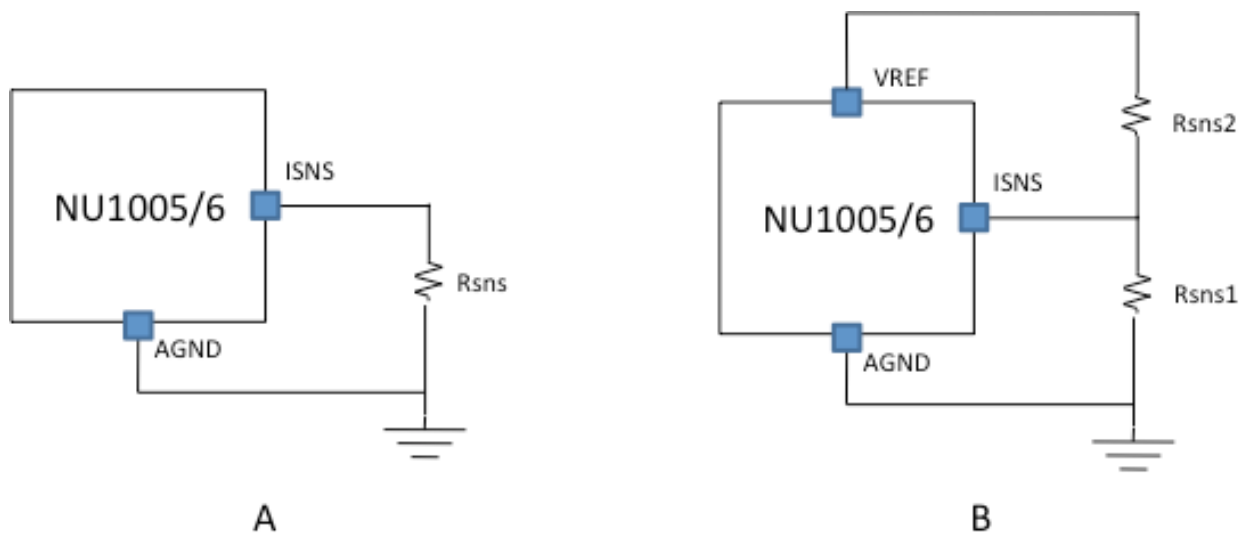

Figure 11. ISNS pin resistor connection

A pull-up resistor, as shown in Circuit B of Fig.11, can be used to create a DC bias voltage for the current signal. The DC bias voltage is given by

$$V_{sns_dc} = V_{REF} * \frac{R_{sns1}}{R_{sns1} + R_{sns2}}$$

The current to voltage conversion gain of ISNS is equal to the paralleled resistance of R_{sns1} and R_{sns2} .

A minimum resistor load of $5K\Omega$ is recommended for the VREF output to ensure the accuracy of the I_{SNS} output.

8.6 Layout Guidelines

Careful PCB layout is critical to system operation. Many references are available on proper PCB layout techniques.

The NU1005/6 layout requires a 4-layer PCB layout for adequate ground plane. A 2-layer PCB can also be achieved at the cost of larger PCB size.

- Layer 1: Component placement, major routing and as much ground plane as possible
- Layer 2: Minor routing and clean ground
- Layer 3: Minor routing and clean ground
- Layer 4: Minor routing and clean ground

Additionally, here are the guidelines to follow:-

- Make routing loop as small as possible, especially the power loop, to minimize EMI noises.
- Place the signal trace on layer 2 or layer 3 to avoid noise coupling.
- Widen the copper between SW1, SW2 and LC tank, because the high current in LC tank can cause power losses on the traces and hence low efficiency. Moreover, the Vin routing should be as wide as possible.
- Separate the analog ground plane from the power ground plane, and use only one point to join them. Please refer to the R23 of Figure 12.
- The full-bridge power stage is integrated in NU1005/6, so thermal vias are needed to provide a thermal path for the NU1005/6
- Place small size of input capacitors as close as possible between the Vin pin and PGND pin. These capacitors can effectively filter out high-frequency noises due to its low ESR and ESL. Please refer to C4 and C6 of Figure 13.
- Keep analog ground plane and power ground plane low impedance. Use as much copper as possible and an appropriate number of vias.

9 Typical Application Circuit

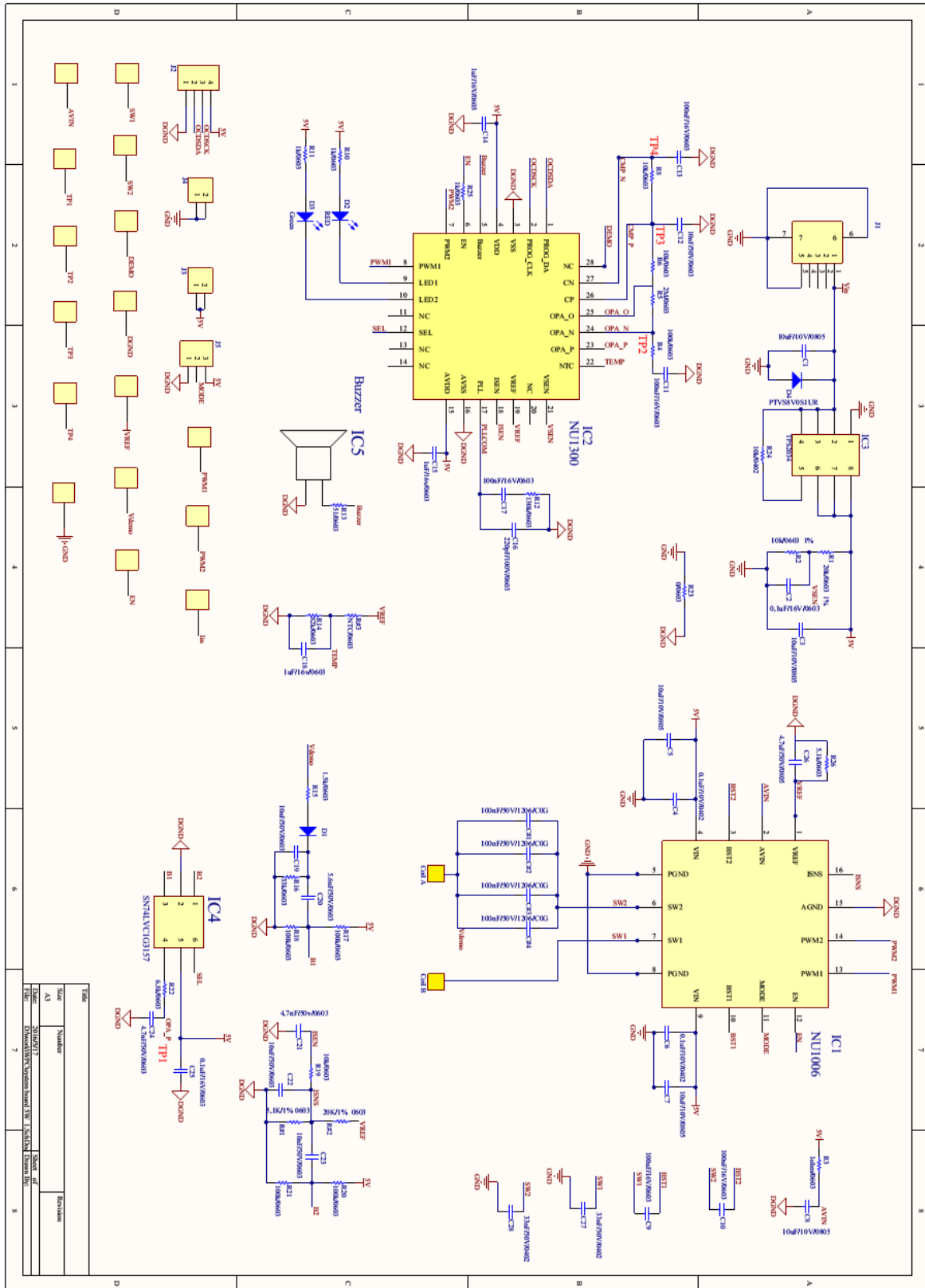

10 Layout Examples

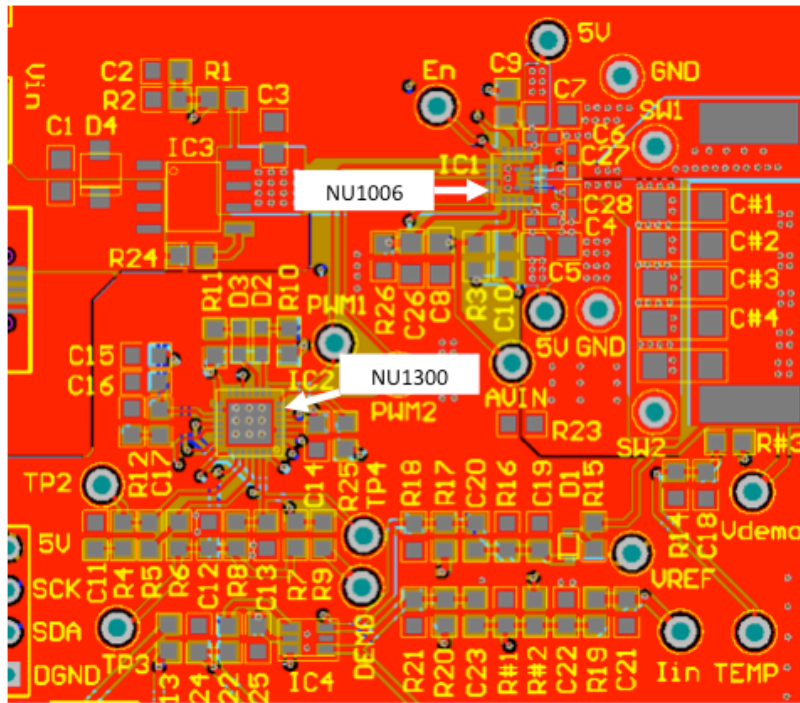

Figure 12 Top Layer

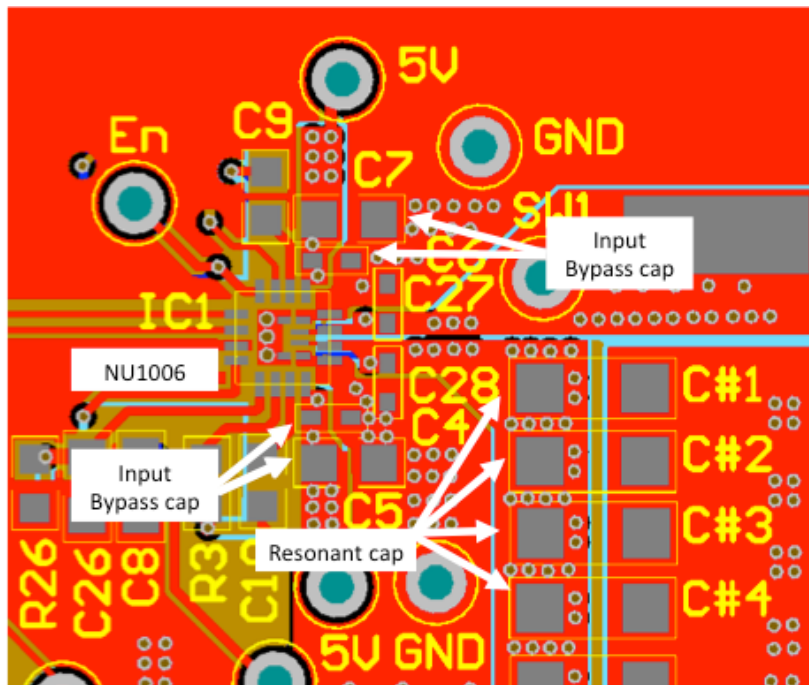

Figure 13 NU1005/6 Bypass Capacitor Layouts

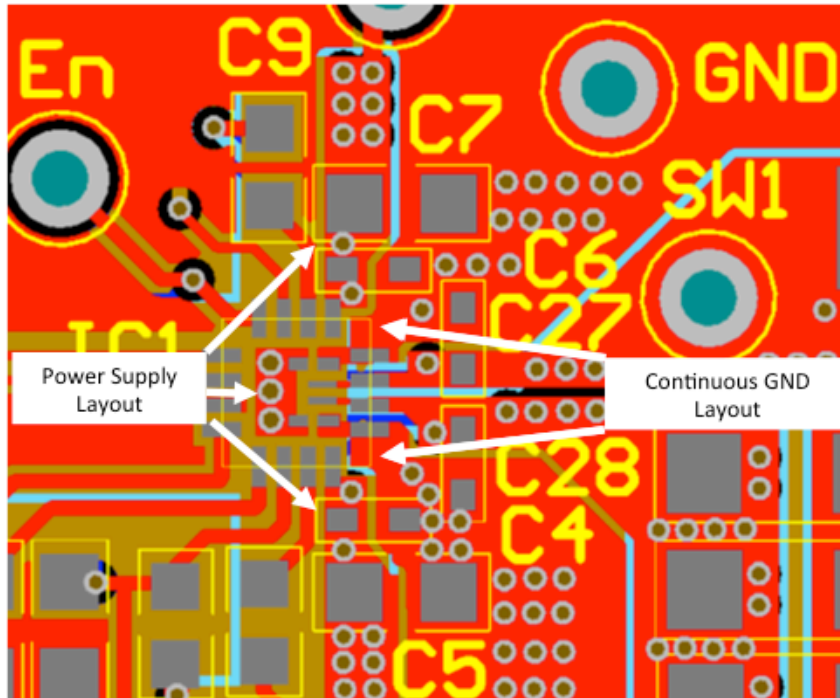

Figure 14 NU1005/6 Power Supply and Ground Layout

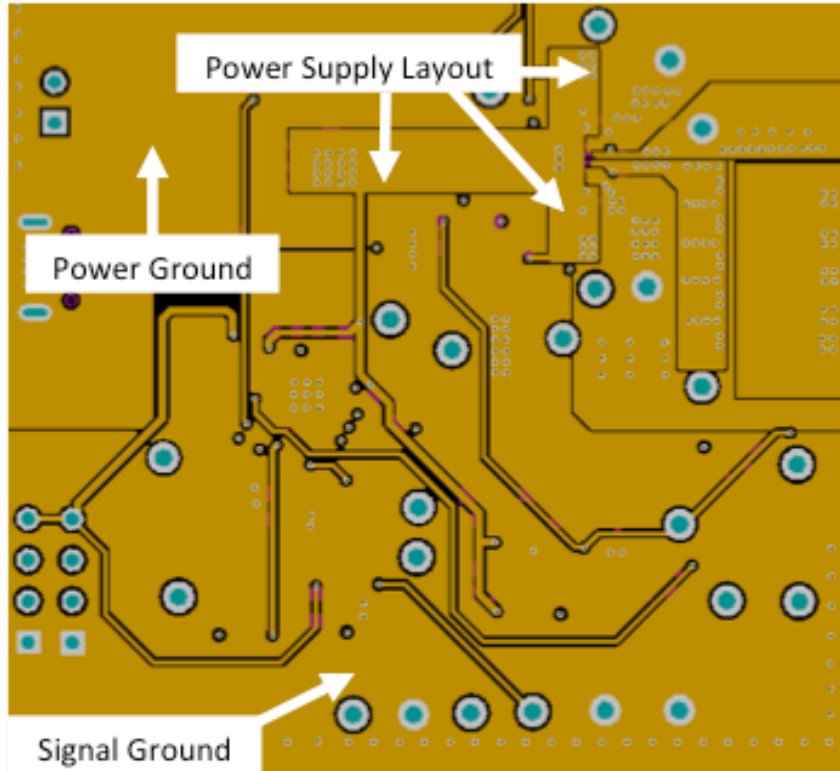

Figure 15 Layer 2

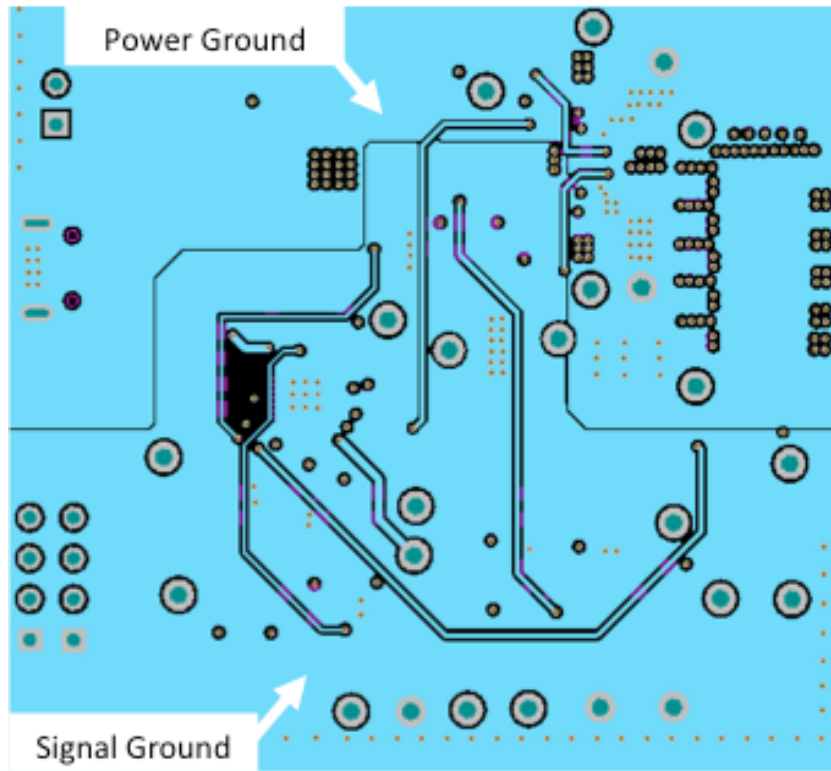

Figure 15 Layer 3

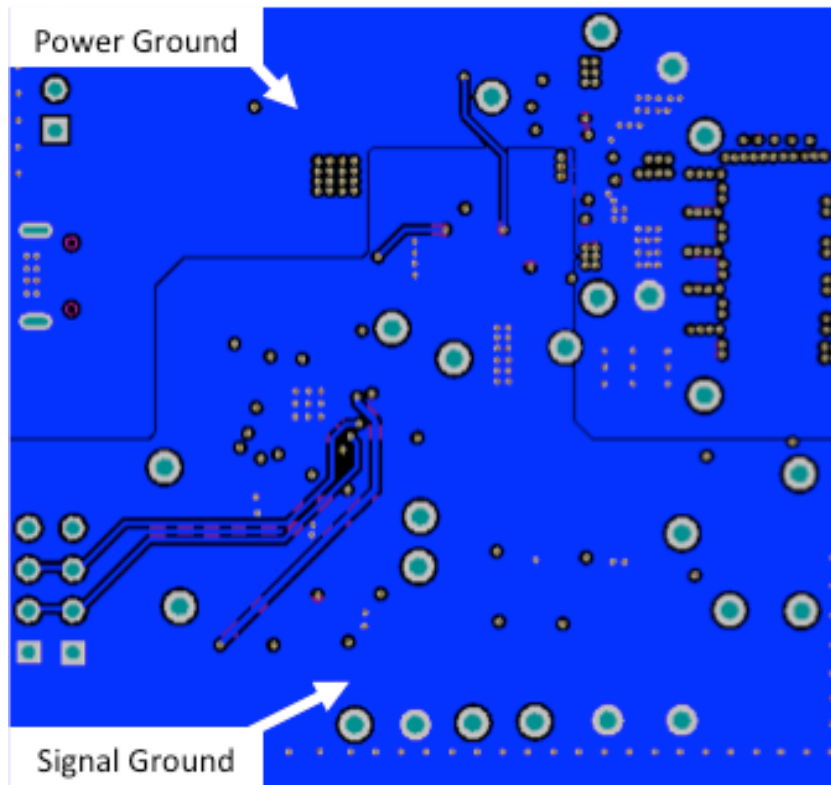
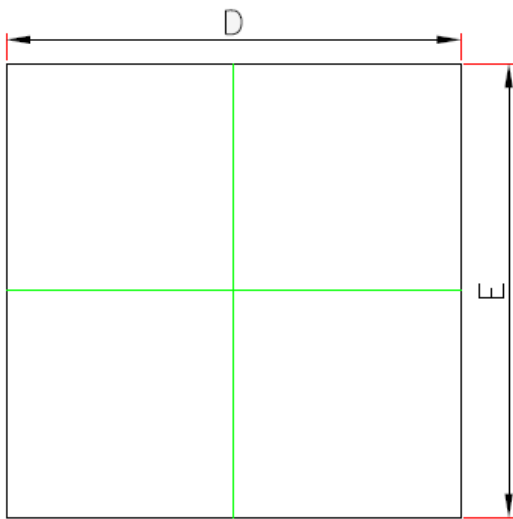

Figure 16 Bottom Layer

11 Package Information

Orderable Device	Status	Package Type	Package Drawing	Pins	Package Quantity	Eco Plan	Lead/Ball Finish	MSL Peak Temp	Op Temp ©	Device Marking
NU1006QDCB	ACTIVE	QFN	QDC	16	3000	Green (RoHS & no Sb/Br)	NiPdAu	Level-3	-40 to 125	NU1006QDC
NU1006QDCS	ACTIVE	QFN	QDC	16	250	Green (RoHS & no Sb/Br)	NiPdAu	Level-3	-40 to 125	NU1006QDC
NU1005QDCB	ACTIVE	QFN	QDC	16	3000	Green (RoHS & no Sb/Br)	NiPdAu	Level-3	-40 to 125	NU1005QDC
NU1005QDCS	ACTIVE	QFN	QDC	16	250	Green (RoHS & no Sb/Br)	NiPdAu	Level-3	-40 to 125	NU1005QDC

12 Mechanical Data



Top view

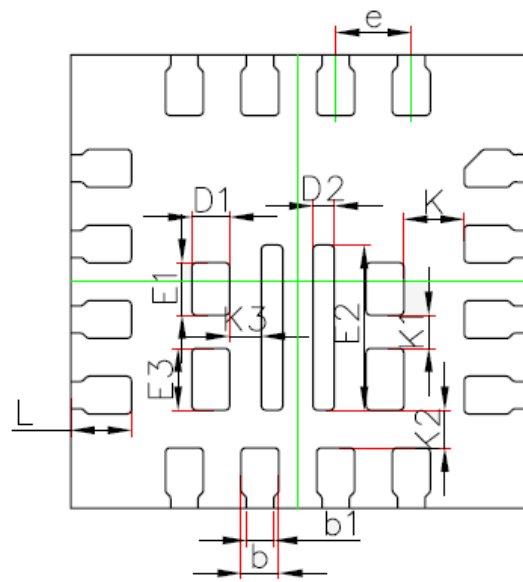

Bottom view

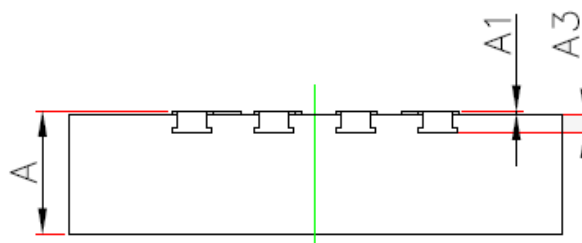

Side view

Symbol	Dimensions In Millimeters		Dimensions in Inches	
	Min	Max	Min	Max
A	0.700	0.800	0.028	0.031
A1	0.004	0.046	0.000	0.002
A3	0.110REF		0.004REF	
D	2.900	3.100	0.114	0.122
D1	0.150	0.350	0.006	0.014
E	2.900	3.100	0.114	0.122
E1	0.248	0.448	0.010	0.018
D2	0.041	0.241	0.002	0.009
E2	0.993	1.193	0.039	0.047
E3	0.309	0.509	0.012	0.020
b	0.200	0.300	0.008	0.012
b1	0.130	0.230	0.005	0.009
e	0.500TYP		0.020TYP	
L	0.300	0.500	0.012	0.020
k	0.399REF		0.016REF	
k1	0.220REF		0.009REF	
k2	0.250REF		0.010REF	
K3	0.210REF		0.008REF	

13 Revision Histories

Revision No.	Date	Changes
V1.0	5/21/16	First Draft
V1.1	1/19/17	Wording changes