

5W Qi V1.2.2-Compliant Wireless Power Receiver and Power Supply

1. Features

- Integrated Wireless Power Supply Receiver Solution
 - High Efficiency Full Synchronous Rectifier
 - Output Voltage Conditioning
 - WPC Qi V1.2.2 Compliant communication
 - Control
 - Single IC Required Between RX Coil and Output
- WPC Qi V1.2.2 FOD Function
- Support I²C Internal Register Configuration
 - Output Voltage -VRECT
 - Output Current - IOUT
- Dynamic Rectifier VRECT
 - Improve the Load Transient Response
 - Optimize the dynamic efficiency for full load output
- Rectifier Overvoltage Clamp (V_{OVP}=15V)
- Support 20 V Maximum Input
- Over Temperature, Over Voltage and Over Current Protection
- Open Drain LED Output Indication
- Multifunction NTC and Temperature Monitoring, Charge Complete and Fault Host Control
- Compatible with Adapter and USB Input Application
- QFN 4mm*4mm 24Pin Pack

2. Applications

- Wearable product
- Cell Phone, Smart Phone
- Hand-held Device
- Portable Products (Audio, Media, Headsets)

3. Description

- CP2031 is a single-chip, advanced, flexible, secondary-side device for wireless power transfer in portable applications capable of providing up to 4 W. It has high integration, high efficiency, low power consumption.
- CP2031 receiver the power that uses the near field electromagnetic induction principle, the power transfer is through coupling between the transmitter coil (primary) and receiver coil (secondary), Global feedback is established from the secondary to the primary to control the power transfer process using the Qi V1.2.2 protocol.
- CP2031 integrated a low resistance synchronous rectifier (AC to DC), low-dropout regulator (LDO), digital control, and accurate voltage and current loops to improve the high efficiency and decrease the power dissipation.
- CP2031 also integrated a digital controller that comply with the WPC V1.2.2 standard, it can calculate the amount of power received by the mobile device, the controller then communicates this information to the transmitter to allow the transmitter to determine if a foreign object is present within the magnetic interface and introduces a higher level of safety within magnetic field. This foreign object detection (FOD) method is part of requirement under the WPV V1.2.2 specification.
- CP2031 Output stage is LDO, the output voltage is adjusted dynamically according to the output current to achieve the best transient and efficiency.
- CP2031 supports I²C internal register configuration, The output voltage and current can be flexibly configured according to the application case

4. Application Schematics

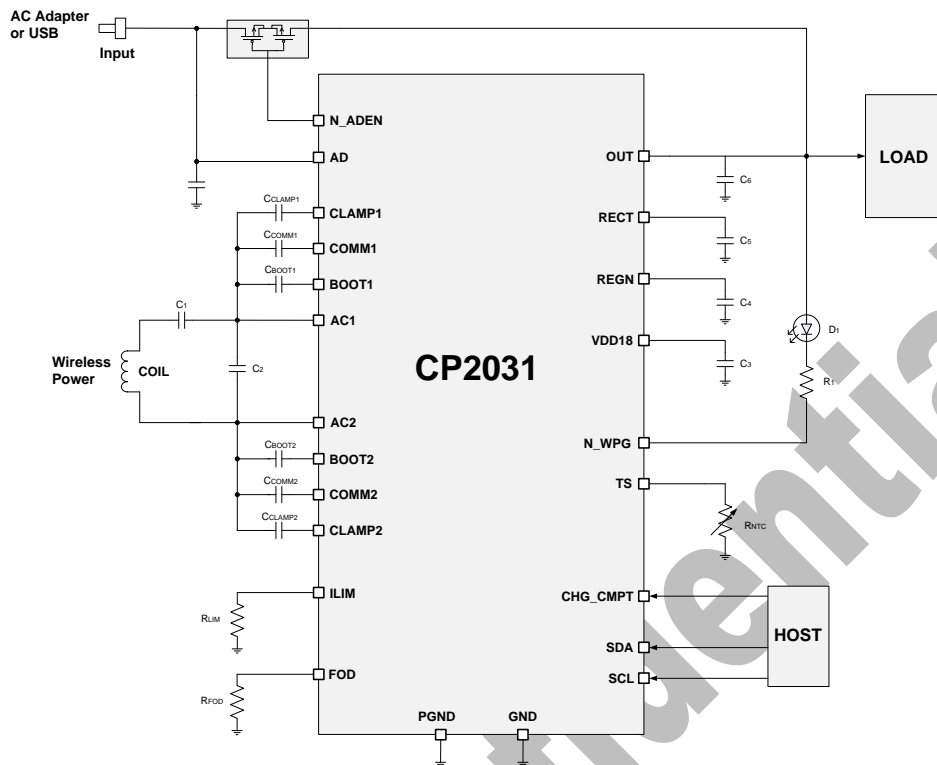

Figure 1. CP2031 application schematics

5. Package and Pin Description

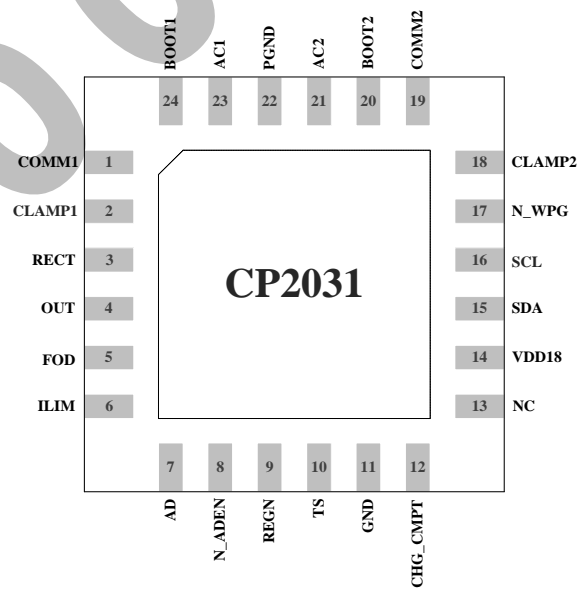

Figure 2. 24 Pin QFN Top View

Table1: Pin Description

Pin Name	RHL	I/O	Description
AC1	23	I	AC input from receiver coil.
AC2	21	I	
BOOT1	24	O	Bootstrap capacitors for driving the high side FETs of the synchronous rectifier. Connect a 10nF capacitor from BOOT1 to AC1 and BOOT2 to AC2.
BOOT2	20	O	
RECT	3	O	Filter capacitor for the inter rectifier. Connect to PGND with 22uF capacitor.
OUT	4	O	Power output, delivers power to the load.
COMM1	1	O	Open drain output used to communication with TX coil by varying reflected impedance. Connect through a capacitor to either AC1 or AC2 for capacitive load modulation.
COMM2	19	O	
CLAMP1	2	O	Open drain FETs which are utilized for over voltage AC clamp protection
CLAMP2	18	O	
AD	7	I	Adapter or USB input.
N_ADEN	8	O	Push-pull driver for external PFET connecting AD and OUT. This voltage tracks approximately 4V below AD when effective voltage is present at AD pin. Float this pin if unused.
PGND	22		Power ground.
GND	11		Analog ground.
ILIM	6	I/O	Programming pin for the over current limit. Connect external resistor to GND. Sizing the RILIM with the following equation: $RILIM=1.2K/IMAX$, IMAX is the Maximum output current.
FOD	5	I	Input for receiver power measurement.
TS	10	I	Temperature Sense (TS) functionality. If an NTC function is not desired, connect to PGND with a 10-kΩ resistor, See Temperature Sense Resistor Network (TS) for more details.
VDD18	17	O	1.8V power output. Connect to GND with 1uF capacitor
REGN	21	O	5V power output. Connect to GND with 1uF capacitor.
SDA	15	I/O	I ² C data pin.
SCL	16	O	I ² C clock pin.
N_WPG	17	O	Active when output current is being delivered to the load, Open Drain output, OUT pin connects to the pin with a resistor and a LED.
CHG_CMPT	12	I	Charging indicator from load system.
NC	13		NC

6. Specification

6.1 Absolute Maximum Ratings

Table2: Over operating free-air temperature range (unless otherwise noted)

Item(V/I)	Pin Name	Min	Max	Unit
Input Voltage	AC1/2	-0.8	20	V
	RECT, COMM1/2, OUT, CLAMP1/2, N_WPG	-0.3	20	V
	BOOT1/2	-0.3	26	V
	AD, N_ADEN	-0.3	20	V
	FOD, ILIM, TS, CHG_CMPT, SDA, SCL	-0.3	7	V
Input Current	AC1/2		1.5	A
Output Current	OUT		1	A
Sink Current	COMM1/2, CLAMP1/2		500	mA
	N_WPG		15	mA
ESD	HBM		2	KV
	CDM		500	V

1: All voltages are with respect to the VSS terminal, unless otherwise noted.

2: Stresses beyond those listed under Absolute Maximum Ratings may cause permanent damage to the device. These are stress ratings only and functional operation of the device at these or any other condition beyond those indicated under Recommended Operating Conditions is not implied. Exposure to absolute maximum rated conditions for extended periods may affect device reliability.

6.2 Thermal Information

Table3

Symbol	Description	Value	A
θ_{JA}	Thermal Resistance Junction to Ambient	35	$^{\circ}\text{C}/\text{W}$
θ_{JC}	Thermal Resistance Junction to Case	30	$^{\circ}\text{C}/\text{W}$
θ_{JB}	Thermal Resistance Junction to Board	2.4	$^{\circ}\text{C}/\text{W}$
T_J	Operating Junction Temperature	0 to +125	$^{\circ}\text{C}$
T_A	Ambient Operating Temperature	0 to +85	$^{\circ}\text{C}$
T_{STG}	Storage Temperature	-55 to +150	$^{\circ}\text{C}$
T_{LEAD}	Lead Temperature (soldering, 10s)	300	$^{\circ}\text{C}$

6.3 Electrical Characteristics

Over operating free-air temperature range, -40 to 85 $^{\circ}\text{C}$

Parameter		Test Condition	Min	Typ	Max	Unit
RECT						
$V_{RECT-UV}$	V_{RECT} Under Voltage lock-out	$V_{RECT}: 0\text{V} \rightarrow 3.3\text{V}$	2.9	3	3.1	V
	Hysteresis on UV			0.25		
$V_{RECT-CLA}$ MP	V_{RECT} Over Voltage lock-out	$V_{RECT}: 5\text{V} \rightarrow 16\text{V}$	14.15	15	15.5	V
	Hysteresis on OV			6		

Parameter		Test Condition	Min	Typ	Max	Unit
V _{RECT-REG}	Dynamic V _{RECTV} Threshold1	I _{LOAD} < 0.1 X I _{MAX}		V _{OUT} +2		V
	Dynamic V _{RECTV} Threshold2	0.1 X I _{MAX} < I _{LOAD} < 0.2 X I _{MAX}		V _{OUT} +1.5		
	Dynamic V _{RECTV} Threshold3	0.2 X I _{MAX} < I _{LOAD} < 0.4 X I _{MAX}		V _{OUT} +0.5		
	Dynamic V _{RECTV} Threshold4	I _{LOAD} > 0.4 X I _{MAX}		V _{OUT} +0.2		
I _{LOAD-HYS}	I _{LOAD} Hysteresis for dynamic V _{RECT} as a% of I _{MAX}			4%		
V _{RECT-DPM}	Rectifier under voltage protection, restrict I _{OUT} at V _{RECT-DPM}		3.2	3.3	3.4	V
Quiescent Current						
I _{RECT}	Active IC quiescent current consumption at V _{RECT}	I _{LOAD} =0		8	10	mA
		I _{LOAD} =300mA		2	3	
I _Q	Quiescent current at the OUT when wireless power is disable	OUT=4.2V		10	15	μA
ILIM Short Current						
I _{OUT-CL}	Maximum output current limit	Maximum I _{LOAD} that will be delivered for 1mS when I _{LIM} is Short			1.5	A
OUTPUT						
K _{IMAX}	Current programming factor for the hardware protection	$K_{IMAX} = R_{LIM} \times I_{MAX}$	1100	1200	1300	AΩ
ACC _{ILIM}	Current limit accuracy	V _{OUT} =3.8V, I _{LOAD} =0.8A, -20°C-125°C	-7		7	%
TS						
V _{TS}	Internal TS Bias voltage	I _{TS} < 100uA	2	2.2	2.4	V
V _{COLD}	Rising threshold	V _{TS} : 50%→60%	56.5	58.7	60.8	%V _{TS}
	Falling hysteresis			2		
V _{HOT}	Falling threshold	V _{TS} : 20%→15%	18.5	19.6	20.7	
	Rising hysteresis			3		
R _{TS}	V _{TS} output impedance		18	20	22	kΩ
t _{DB-TS}	Deglitch time for TS comparators			10		ms
Rectifier						
I _{LOAD-FULL}	I _{OUT} at which the synchronous rectifier enters half-synchronous mode	I _{LOAD} : 0mA→200mA	105	125	155	mA
	Hysteresis			25		
R _{ON}	Impedence of rectifier FET			100		mΩ
Thermal Protection						
T _{J-OFF}	Thermal shutdown temperature			155		°C
	Thermal shutdown hysteresis			40		

6.4 Typical Application Schematics

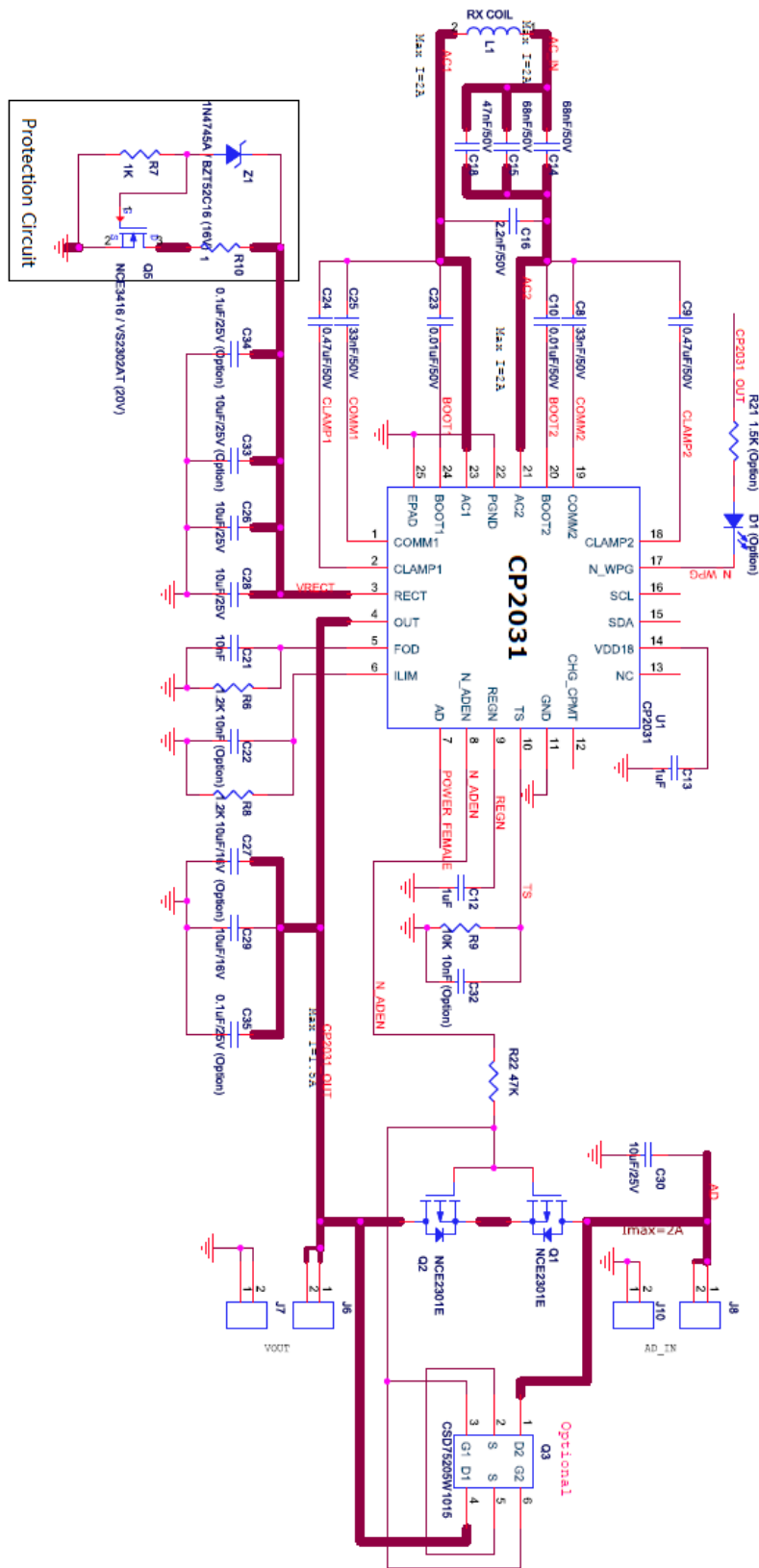

Figure 3. Typical application schematics

6.5 Typical Characteristics

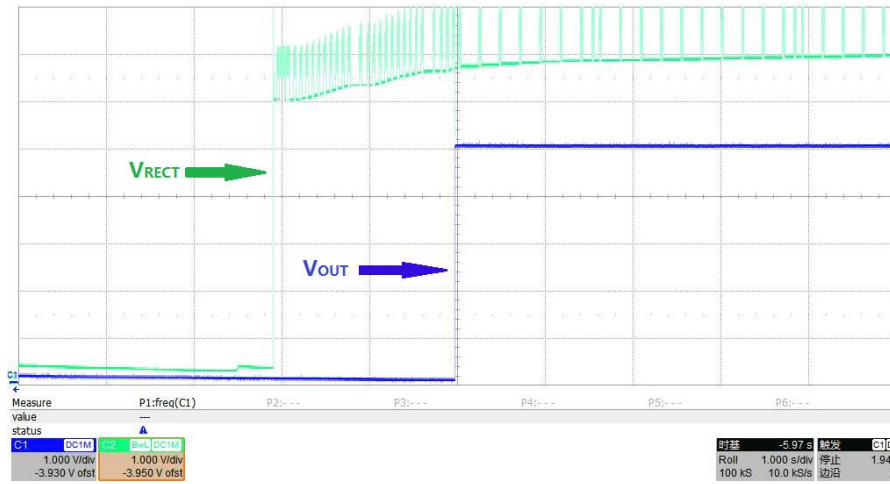

Figure4. Wireless receiver Power ON

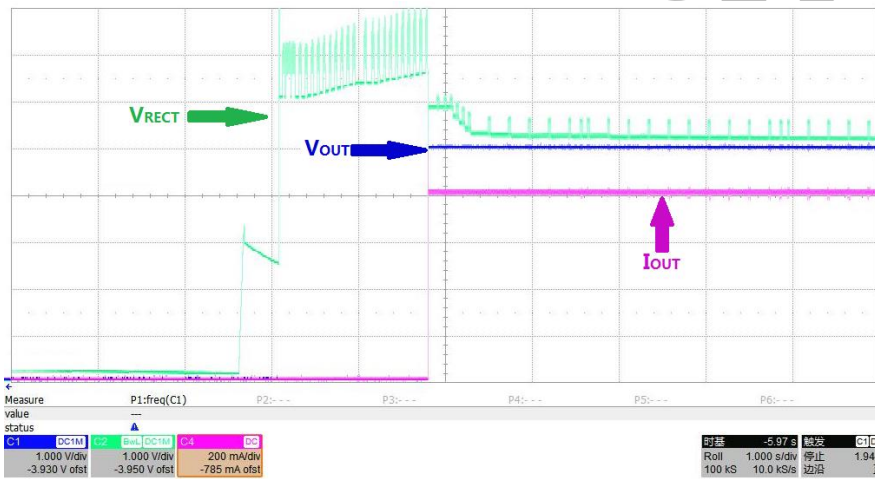

Figure5. Wireless receiver Power ON

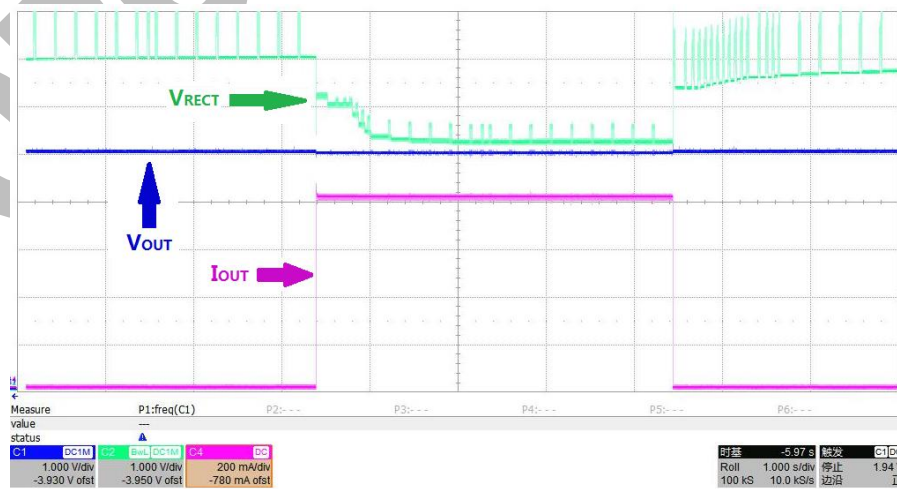

Figure6. 0->800mA Load Transient

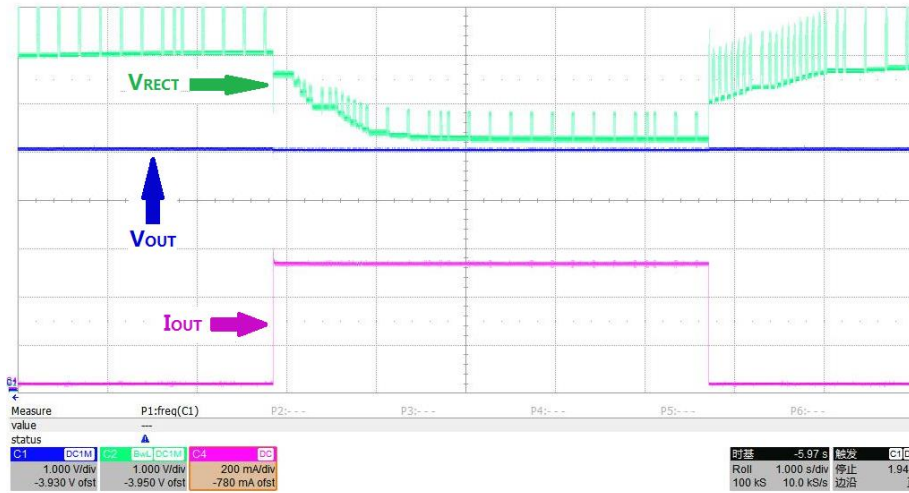

Figure7. 0->500mA Load Transient

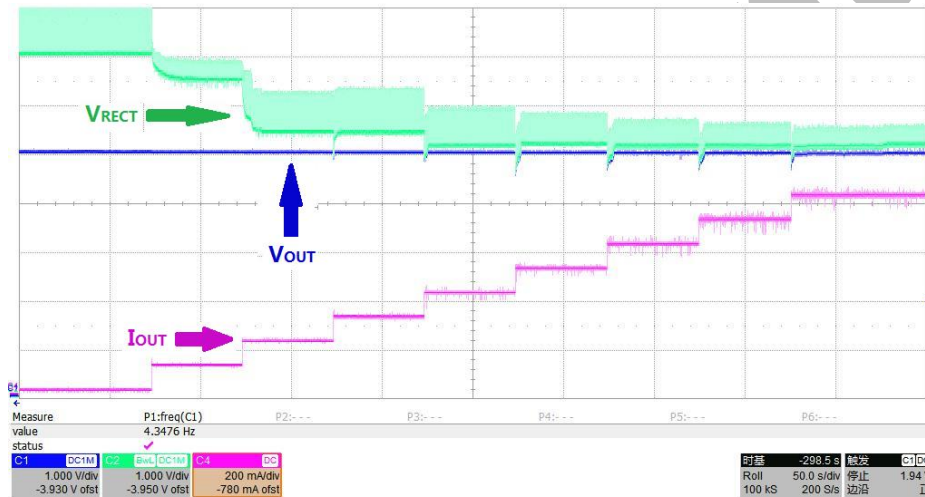

Figure8. V_{RECT} vs. V_{OUT} vs. I_{OUT}

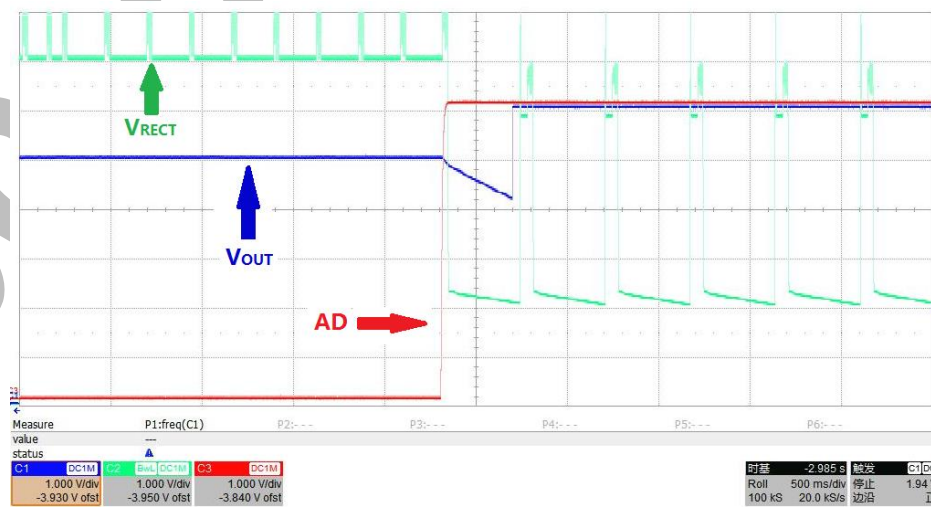

Figure9. AD input (7V) without Load

7. Detail Description

7.1 Principle of wireless power transfer operation

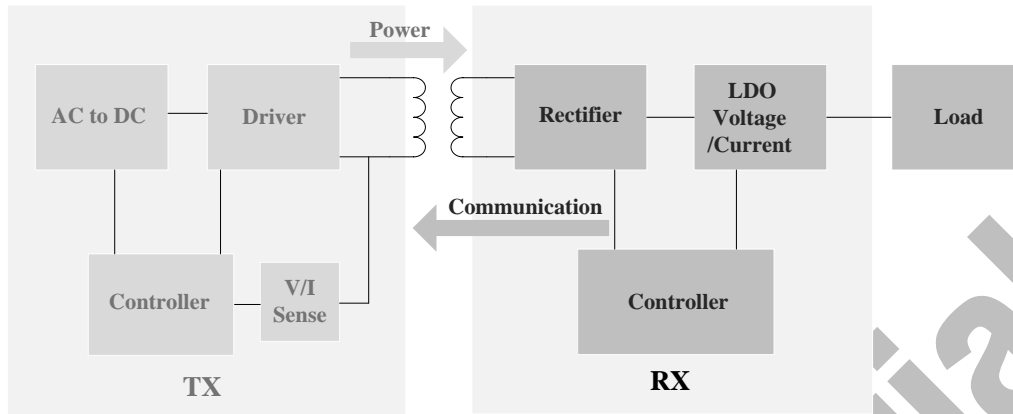

Figure10 . WPC Wireless Power Transmitter and Receiver

A wireless power transfer system consists of a power transmitter (TX or primary) and the power receiver (RX or secondary). There is a coil in the transmitter and in the receiver which are magnetically coupled to each other when the RX is placed on TX. Power is then transferred from the transmitter to the receiver through coupled inductors (effectively an air-core transformer). Controlling the amount of power transferred is achieved by sending feedback (error signal) communication to the primary (to increase or decrease power with the load change).

The receiver communicates with the transmitter by changing the load seen by the transmitter. This load variation results in a change in the transmitter coil current, which is measured and interpreted by a processor in the TX. The communication is digital; packets are transferred from the receiver to the transmitter. Differential bi-phase encoding is used for the packets. The bit rate is 2-kbps.

Various types of communication packets have been defined (WPC Qi V1.2.2). These include identification and authentication packets, error packets, control packets, end power packets, and power usage packets.

The transmitter coil stays powered off most of the time. It occasionally wakes up to see if a receiver is present. When a receiver authenticates itself to the transmitter, the transmitter will remain powered on. The receiver maintains full control over the power transfer using communication packets.

7.2 Feature Description

The wireless power transfer require two stage, the first stage is RX active power transfer stage , the second is power transfer stage between TX and RX, The Figure11 is the RX active power transfer stage flow diagram details. When an RX is present on the TX surface, the RX will then provide the signal strength, configuration and identification packets to the TX (see the WPC specification for details on each packet). Once the TX has successfully received the signal strength, configuration and identification packets, the RX will be granted a power contract and is then allowed to control the operating point of the power transfer. With the use of the CP2031 Dynamic Rectifier Control algorithm, the RX will inform the TX to adjust the rectifier voltage above 7 V prior to enabling the output supply.

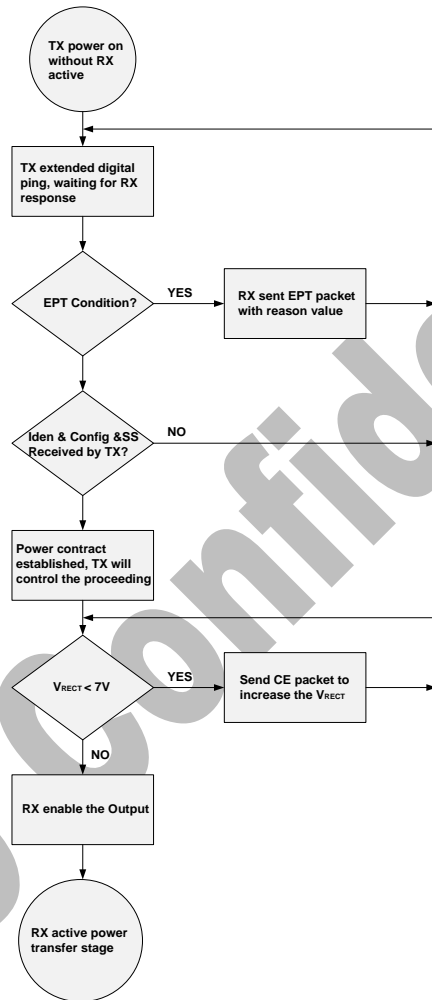

Figure11. WPC Wireless power Start up Flow

When RX active power transfers, The Dynamic Rectifier Control algorithm will determine the rectifier voltage target based on a percentage of the maximum output current level setting (set by KIMAX and the ILIM resistance to GND). The RX will send control error packets in order to converge on these targets. As the output current changes, the rectifier voltage target will dynamically change. The feedback loop of the WPC system is relatively slow where it can t take more than 100 ms level time to converge on a new rectifier voltage target. See Figure12 which illustrates the active power transfer stage.

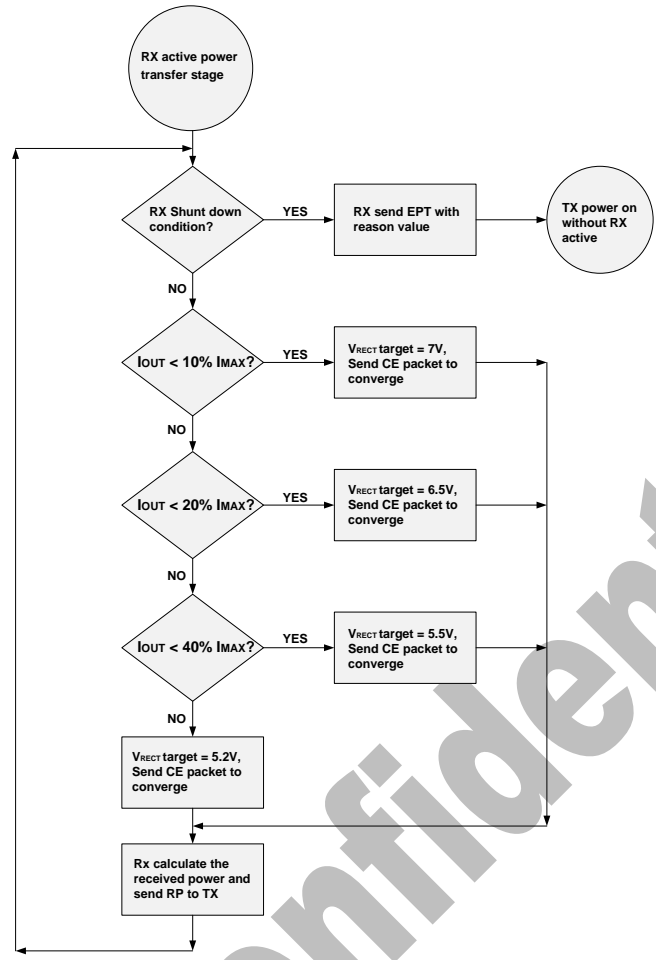

Figure12. WPC Wireless power transfer flow

7.3 Feature Description

7.3.1 Set the I_{MAX}

The CP2031 provides hardware over current protection by means of an analog current regulation loop. The hardware current limit provides an extra level of safety by clamping the maximum allowable output current. The R_{LIM} resistor size also sets the thresholds for the dynamic rectifier levels and thus providing efficiency tuning per each application's maximum system current. The calculation for the total R_{LIM} resistance is as follows:

$$R_{LIM} = K_{IMAX} / I_{MAX}, \text{ where } K_{IMAX}=1200$$

7.3.2 Dynamic Rectifier Control and VRECT Voltage

The Dynamic Rectifier Control algorithm offers the end system designer optimal transient response for a given maximum output current setting. This is achieved by providing enough voltage headroom across the internal regulator at light loads in order to maintain regulation during a load transient. The WPC system has a relatively slow global feedback loop where it can take more than 100 ms level to converge on a new rectifier voltage target. Therefore, the transient response is dependent on the loosely coupled transformers output impedance profile. The Dynamic Rectifier Control allows for a 2 V change in rectified voltage before the transient response will be observed at the output of the internal regulator.

The Dynamic Efficiency Scaling feature allows for the loss characteristics of the CP2031 to be scaled based on the maximum expected output power in the end application. This effectively optimizes the efficiency for each application. This feature is achieved by scaling the loss of the internal LDO based on a percentage of the maximum output current. Note that

the maximum output current is set by the K_{IMAX} term and the R_{ILIM} resistance (where $R_{ILIM} = K_{IMAX} / I_{MAX}$). The table 4 illustrates how the rectifier is dynamically controlled (Dynamic Rectifier Control) based on a fixed percentage of the I_{MAX} setting. Table 1 summarizes how the rectifier behavior is dynamically adjusted based on two different R_{ILIM} settings.

Table 4

I_{OUT} vs. I_{LIM}	V_{RECT}	V_{RECT}	V_{RECT_Target} ($V_{OUT_Target} = 5V$)
$I_{OUT} < 10\% I_{LIM}$	$V_{TARGET1}$	$V_{OUT} + 2 V$	7 V
$10\% I_{LIM} < I_{OUT} < 20\% I_{LIM}$	$V_{TARGET2}$	$V_{OUT} + 1.5 V$	6.5 V
$20\% I_{LIM} < I_{OUT} < 40\% I_{LIM}$	$V_{TARGET3}$	$V_{OUT} + 0.5 V$	5.5 V
$I_{OUT} > 40\% I_{LIM}$	$V_{TARGET4}$	$V_{OUT} + 0.2 V$	5.2 V

7.3.3 Adapter/USB Function

CP2031 used as wireless power receiver can power multiplex between wired or wireless power for the down-system electronics. If an adapter is not present the AD pin will be low, and N_ADEN pin will be pulled to the higher of the OUT and AD pin so that the PMOS between OUT and AD will be turn off. If an adapter is plugged in and the voltage at the AD pin goes above 3.6 V, then wireless charging is disabled and the N_ADEN pin will pulled approximately V_{AD} blow the AD pin to connect AD to the secondary charger. The difference between AD and N_ADEN is regulated to about 5 V to ensure the V_{GS} of the external PMOS is open and protected.

7.3.4 Foreign Object Detection (FOD)

The C2031 is a WPC V1.2 compatible device. In order to enable a power transmitter (TX) to monitor the power loss across the interface as one of the possible methods to limit the temperature rise of foreign objects, the CP2031 will calculates and reports its received power to the power transmitter. The received power equals the power that is available from the output of the Power Receiver plus any power that is lost in producing that output power (the power loss in the secondary coil and series resonant capacitor, the power loss in the shielding of the Power Receiver, the power loss in the rectifier, analog and digital control blocks. In the WPC1.2 specification, foreign object detection (FOD) is enforced. This means the CP2031 will send received power information with known accuracy to the transmitter.

7.3.5 End Power Transfer Packet (WPC Header 0x02)

The WPC allows for a special command for the receiver to terminate power transfer from the transmitter termed End Power Transfer (EPT) packet. Table 5 specifies the V1.2 reasons column and their corresponding data field value. The condition column corresponds to the methodology used by CP2031 to send equivalent message.

Table 5 End power transfer packet

EPT Package	Value	Description
0X00	Unknow	AD plug in
0X01	Charge Complete	Not Sent
0X02	Internal Fault	OUT pin short
		Internal over temperature
		Internal over current
0X03	Over Temperature	TS pin low temperature
		TS pin over temperature
0X04	Over Voltage	RECT pin over voltage
0X05	Over Current	Not Sent

EPT Package	Value	Description
0X06	Battery Failure	Not Sent
0X07	Reconfigure	Not Sent

7.3.6 Status Output N_CHG

The CP2031 has one status output pin named N_CHG. This output is an open-drain NMOS device that is rated to 20 V. The open-drain FET connected to the N_CHG pin will be turned on whenever the output of the power supply is enabled. The output of the power supply will not be enabled. The power of N_CHG can be supplied by RECT or OUT.

7.3.7 Communication Modulator

The WPC communication uses a modulation technique termed “back-scatter modulation” where the receiver coil is dynamically loaded in order to provide amplitude modulation of the transmitter's coil voltage and current. CP2031 supports capacitor modulation mode as figure 13 shows. The capacitor modulation mode can maintain high efficiency without affecting communication.

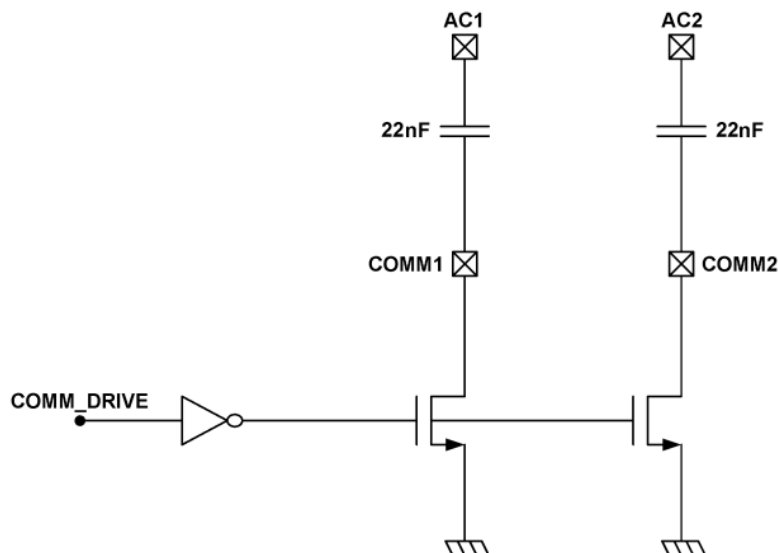

Figure13. WPC Capacitive Load Modulation

7.3.8 Synchronous Rectification

The CP2031 provides an integrated, self-driven synchronous rectifier that enables high-efficiency AC to DC power conversion. The rectifier consists of an all NMOS H-Bridge driver where the backgates of the diodes are configured to be the rectifier when the synchronous rectifier is disabled. During the initial start-up of the WPC system the synchronous rectifier is not enabled. At this operating point, the DC rectifier voltage is provided by the diode rectifier. Once V_{RECT} is greater than V_{UVLO} , half synchronous mode will be enabled until the load current surpasses $I_{FBR-MODE}$. Above $I_{FBR-MODE}$ the full synchronous rectifier stays enabled until the load current drops back below the hysteresis level ($I_{FBR-MODE}$) where half-synchronous mode is enabled re-enabled.

7.3.9 Internal Temperature Sense (TS)

CP2031 includes a external temperature sense function. The temperature sense function has two ratio-metric thresholds

which represent a hot and cold condition. An external temperature sensor is recommended in order to provide safe operating conditions for the receiver application. This pin is best used for monitoring the surface that can be exposed to the end user (place the NTC resistor closest to where the user would physically contact the end product).

7.3.10 Thermal Protection

The CP2031 includes a thermal shutdown protection. If the die temperature reaches T_{J-SD} , the LDO is shut off to prevent any further power dissipation. In this case CP2031 will send an EPT message of internal fault (0x02). Once the temperature falls T_{J-Hys} below T_{J-SD} , the system will work again.

7.3.11 Charge Complete Function

CP2031 can be controlled by external controllers using CHG_CMPT PIN. The CHG_CMPT is an external control pin that pulls low by the internal 200kOhm resistor. When the external MCU or Charger set it high, power output of CP2031 will be closed, and send EPT type package to the power transmitter (PTX), notify it power down.

7.3.12 Series and Parallel Resonant Capacitor Selection

Shown in Figure 14, the capacitors C1 (series) and C2 (parallel) make up the dual resonant circuit with the receiver coil. These two capacitors must be sized correctly per the WPC V1.2 specification.

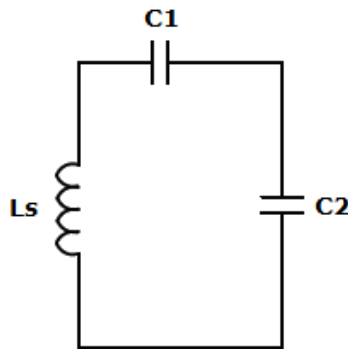

Figure14. Resonant Circuit of the Receiver Coil

C1 and C2 can be calculated using the following Equation:

$$C1 = \frac{1}{(2\pi \times Fs)^2 \times Ls}$$

$$C2 = ((2\pi \times Fd)^2 \times Ls - \frac{1}{C1})^{-1}$$

$Fs=100\text{KHz}$ (+5/-10%), $Fd=1\text{MHz}$ (+-10%), The quality factor can be determined by the following Equation:

$$Q = \frac{2\pi \times Fd \times Ls}{R}$$

R is the DC resistance of the receiver coil.

8. Package Information

QFNWB4x4-24L(P0.50T0.75/0.85) Package Outline Dimensions

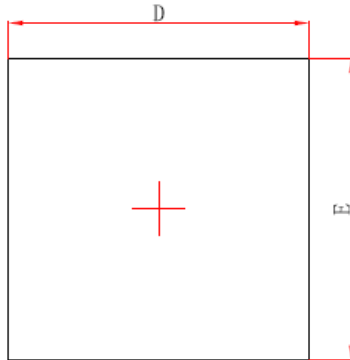

Top View

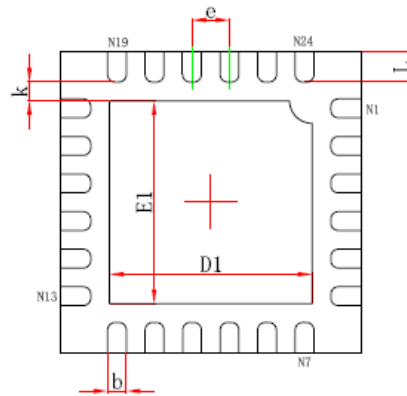

Bottom View

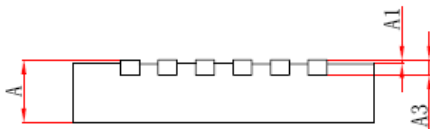

Side View

Symbol	Dimensions In Millimeters		Dimensions In Inches	
	Min.	Max.	Min.	Max.
A	0.700/0.800	0.800/0.900	0.028/0.031	0.031/0.035
A1	0.000	0.050	0.000	0.002
A3	0.203REF.		0.008REF.	
D	3.924	4.076	0.154	0.160
E	3.924	4.076	0.154	0.160
D1	2.600	2.800	0.102	0.110
E1	2.600	2.800	0.102	0.110
k	0.200MIN.		0.008MIN.	
b	0.200	0.300	0.008	0.012
e	0.500TYP.		0.020TYP.	
L	0.324	0.476	0.013	0.019

9. REVISION HISTORY

Date	Revision #	Description	Page
2016.12	1.0	Original	6
2017.3	1.1	Modify and Update the Typical Application Schematics	6
2017.12	1.2	Modify and Update the Typical Application Schematics	6
2018.2	1.3	Add protection circuit in the Typical Application Schematics for mid-power TX	6

COPOL Confidential